



Low Heat Load, High Efficiency;

Fiber-based architecture, High Reliability;

Compact;

System Specifications		BL526-200
Wavelength		526.5 nm
Output Power		200 mW
Beam Diameter ¹		~ 2 mm
Transverse mode		TEM ₀₀
Beam divergence ²		< 1.5 mrad
M ² factor		M ² < 1.2
Noise		N/A
Point stability ³		< 0.05 mrad
Polarization ratio		> 100:1
Power stability ⁴		< 5%; 10% @ 4 hours
Beam Height		25 mm
Warm-up time		10 minutes
Expected lifetime		10,000 hours
Warranty time		1 year
Operating temperature		10-45°C
Power supply		80 - 264 VAC or 5 VDC
Power Consumption		N/A
Dimensions (L×W×H)	Laser Head	140 × 73 × 46 mm
	Power Supply	154 × 155 × 95 mm
Weights	Laser Head	0.6 Kg
	Power Supply	1.5 Kg

NOTES

All specifications at 526.5 nm unless otherwise noted. All performance specifications guaranteed at specified output power only.

1 1/e² at exit port.

2 Full-angle divergence.

3 Measured as far-field x and y positions over a 25°C to 35°C temperature change.

4 Measured over 4 hours after 15 minute warm-up.

526.5nm

CW Green Lasers

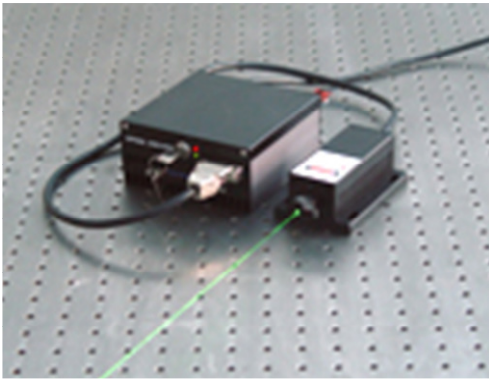

This 526.5 nm CW Blue/Green Laser is a Diode-Pumped Solid-State (DPSS) Laser with Compacted, Rugged and Air-cooled geometry. The laser system includes one Laser Driver and one Laser Head, they are connected with a cable for compliance with FDA regulations as an OEM laser product, and can be operated over a wide temperature range with a Low Noise and High Stability laser output.

Laser Head



140.8(L)×73(W)×46.2(H) mm³, 0.6kg

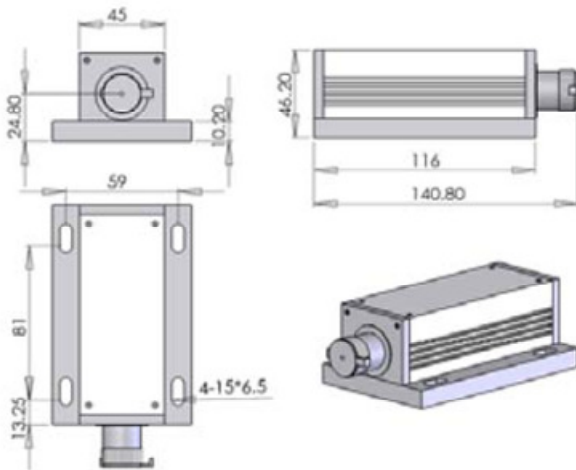

Power Supply



154 (L) ×155(W) ×95 (H) mm³, 1.5kg

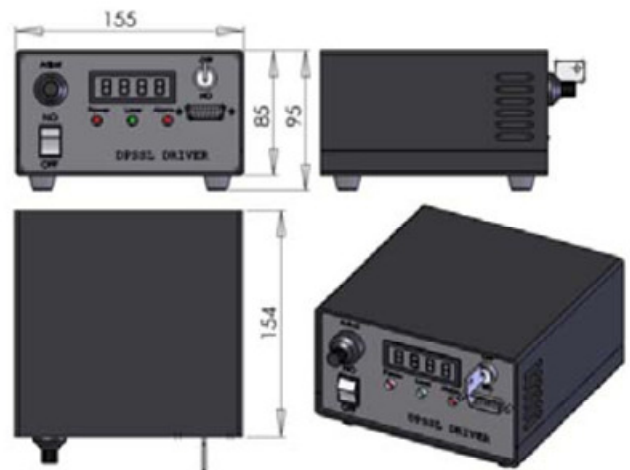

All Dimensions are in mm

Laser Lab Components, Inc. (LLCI) follows a policy of continuous product improvement. Specifications are subject to change without notice.

LLCI offers a limited warranty for all GL™ systems. For full details on warranty coverage, please refer to the Service and Support section at www.LaserLabComponents.com, or contact our Sales or Service Representative.

www.LaserLabComponents.com

