



5-50mW Output

Low Divergence, Low Noise

Diode Pumped, Compact

System Specifications	YL556 -25	YL556-50
Wavelength	556 nm	556 nm
Output Power	25 mW	50 mW
Beam Diameter at the aperture	~2.0 mm	~2.0 mm
Transverse mode	TEM ₀₀	Near TEM ₀₀
Beam divergence	<1.5 mrad	<1.5 mrad
M ² factor	M ² ≤ 1.2	M ² ≤ 1.2
Beam Height (mm)	25 mm	25 mm
Operating Temperature	10 - 35 degree C	10 - 35 degree C
Point stability after warm-up	<0.05mrad	<0.05mrad
Polarization ratio	> 100:1	> 100:1
Power stability (4 Hrs)	< 3%, 5%	< 5%, 10%
Warm-up time (Minutes)	< 10	<10
Expected lifetime	10,000 hours	10,000 hours
Warranty time	1 year	1 year

	Specifications	
Utility and Environmental Requirements	Power supply	80-260VAC or 5VDC
	Power Consumption	50W
	Operating temperature	10-35°C
	Dimensions(L×W×H)	
	Laser Head	140×75×45mm
	Power Supply	154×160×95mm
	Weights	
	Laser Head	0.6Kg
	Power Supply	1.5Kg

556nm

CW Yellowish Lasers

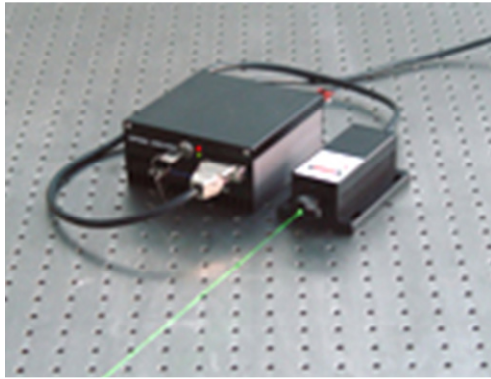

This 556 nm CW Yellow Laser is a Diode-Pumped Solid-State (DPSS) Laser with Compacted, Rugged and Air-cooled geometry. The laser system includes one Laser Driver and one Laser Head, they are connected with a cable for compliance with FDA regulations as an OEM laser product, and can be operated over a wide temperature range with a Low Noise and High Stability laser output.

Laser Head



140. 8(L)×73(W) ×46. 2(H) mm³, 0.6kg

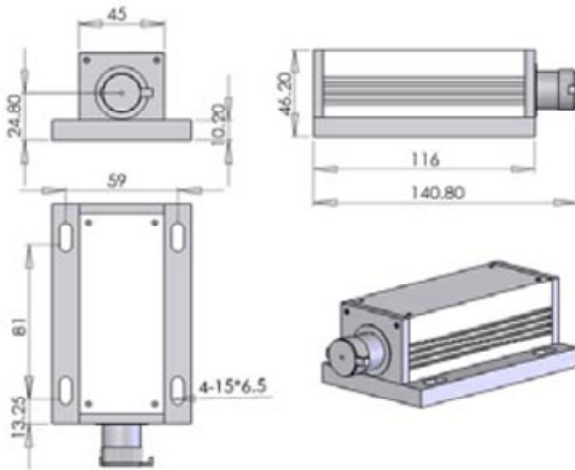

Power Supply



154 (L) ×155(W) ×95 (H) mm³, 1.5kg

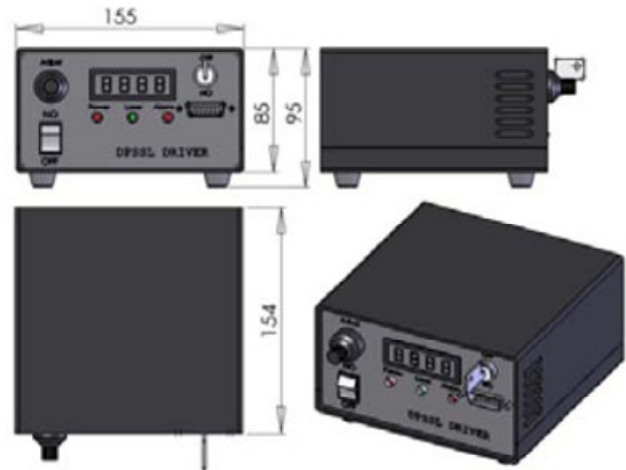

All Dimensions are in mm

Laser Lab Components, Inc. (LLCI) follows a policy of continuous product improvement. Specifications are subject to change without notice.

LLCI offers a limited warranty for all GL™ systems. For full details on warranty coverage, please refer to the Service and Support section at www.LaserLabComponents.com, or contact your local Sales or Service Representative.

www.LaserLabComponents.com^d

