



100 - 800mW Output

Low Divergence, Low Noise

Diode Pumped, Compact, Air-Cooled

QUV 355

System Specifications		QUV 355
Wavelength		355nm
Average Output Power		100 - 800mW
Pulse Repetition Rate		5-20KHz
Pulse Width		< 15 ns @ 20 kHz
Beam Diameter ¹		2.0 mm
Transverse mode		Near TEM ₀₀
Beam Height		94 mm
M ² factor		M ² ≤ 1.5
Point stability ³		< 0.05mrad
Polarization ratio		> 100:1
Power stability ⁴		5%, 10% @ 4 hours
Warm-up time		< 15 minutes
Expected lifetime		8,000 hours
Warranty time		1 year
Operating temperature		10-35°C
Power supply		80-260VAC
Power Consumption		< 500W
Dimensions (L×W×H)	Laser Head	333 × 140 × 125 mm
	Power Supply	300 × 162 × 134 mm
Weights	Laser Head	6.1 Kg
	Power Supply	5.2 kg

NOTES

All specifications at 355 nm unless otherwise noted. All performance specifications guaranteed at specified output power only.

1 1/e² at exit port.

2 Full-angle divergence.

3 Measured as far-field x and y positions over a 25°C to 35°C temperature change.

4 Measured over 4 hours after 15 minute warm-up.

355nm

QCW Ultraviolet Lasers



Laser Head



333(L)×140(W) ×125(H) mm³, 6.1 kg

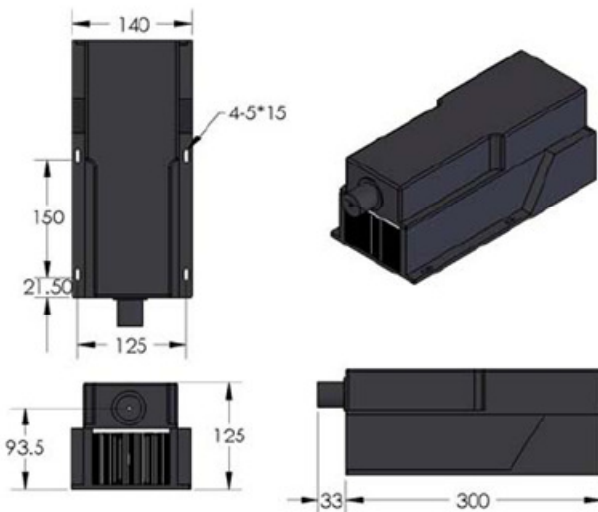

Power Supply



300 (L) ×162(W) ×134(H) mm³, 5.2 kg

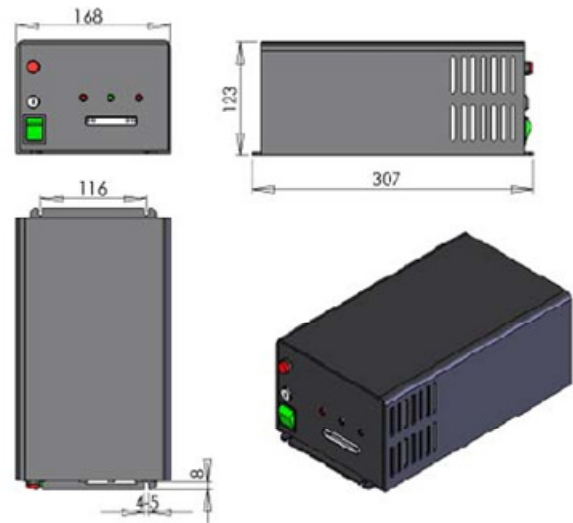

All Dimensions are in mm

Laser Lab Components, Inc. (LLCI) follows a policy of continuous product improvement. Specifications are subject to change without notice.

LLCI offers a limited warranty for all GL™ systems. For full details on warranty coverage, please refer to the Service and Support section at www.LaserLabComponents.com, or contact your local Sales or Service Representative.

VISIBLE AND INVISIBLE LASER RADIATION.
AVOID EYE OR SKIN EXPOSURE
TO DIRECT OR SCATTERED RADIATION.
CLASS 3B LASER PRODUCT

λ	MAX. POWER
0.52-0.54 μm	500 mW
0.73-0.92 μm	20 mW
1.05-1.07 μm	50 mW

DANGER